

LOC	DIST	P	F	REVISIONS				
				ZONE	LTR	DESCRIPTION	DATE	APPD
AD	39				H	REV PER 0010-1061-94	12-28-96	JH
					J	REV PER 0010-1175-95	12-28-96	JH
					K	REV PER 0310-0398-97	9-25-97	JH

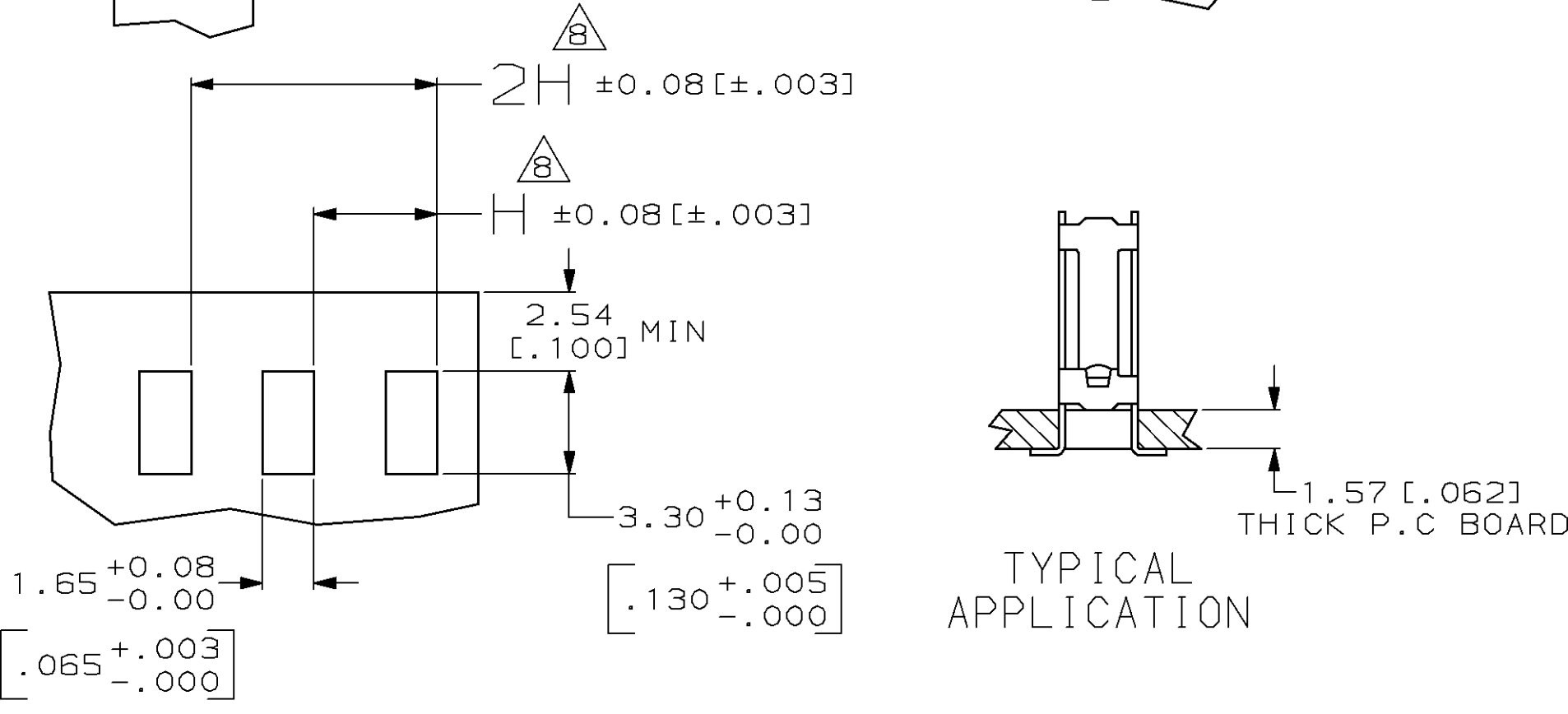

- 1 PHOSPHOR BRONZE 0.25 [.010] COML. FINISH: TIN PLATE
- 2 SHEAR LINES DEFINE LOOSE PIECE PART.
- 3 0.00038 [.000015] GOLD IN CONTACT AREA, 0.00254-0.00508 [.000100-.000200] BRIGHT TIN-LEAD IN TERMINATION AREA, ALL OVER 0.00127 [.000050] NICKEL.
- 4 0.00076 [.000030] GOLD IN CONTACT AREA, 0.00254-0.00508 [.000100-.000200] BRIGHT TIN-LEAD IN TERMINATION AREA, ALL OVER 0.00127 [.000050] NICKEL.
- 5 POINT OF MEASUREMENT FOR PLATING THICKNESS.
- 6 "H", (RECEPTACLE CENTERS) MAY VARY DEPENDING ON REQUIREMENTS, MINIMUM NOMINAL CENTER SPACING BETWEEN ADJACENT RECEPTACLES IS 3.81±0.08 [.150±.003].

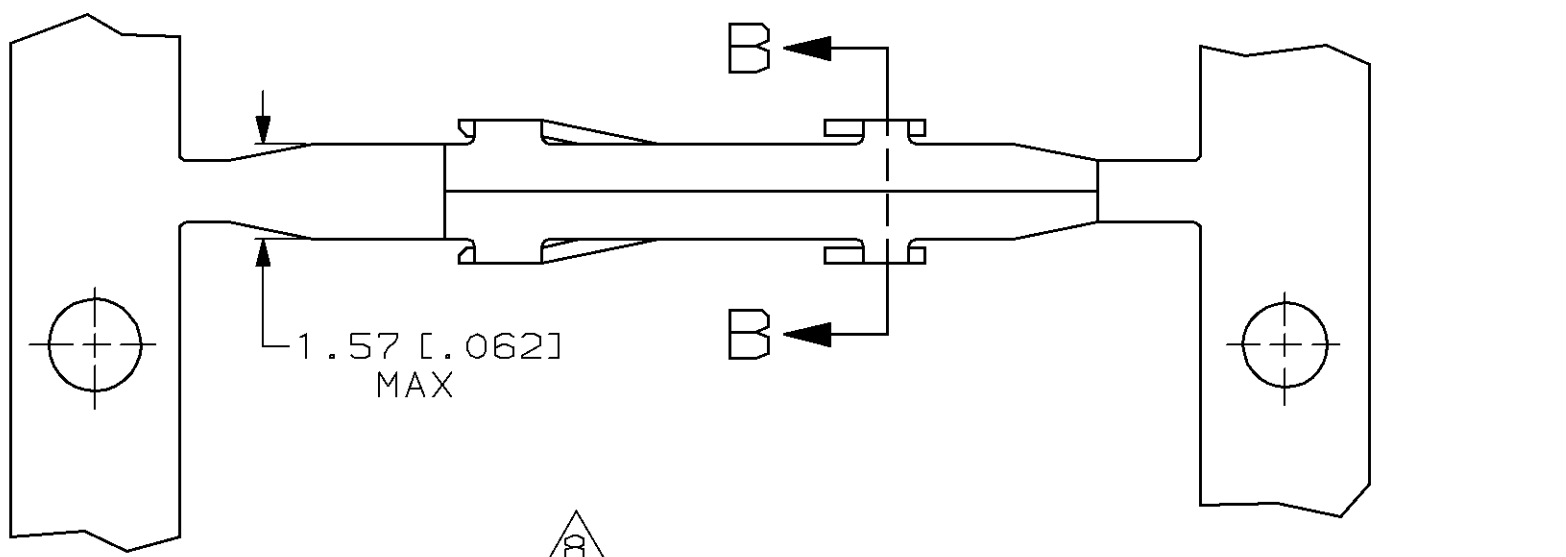
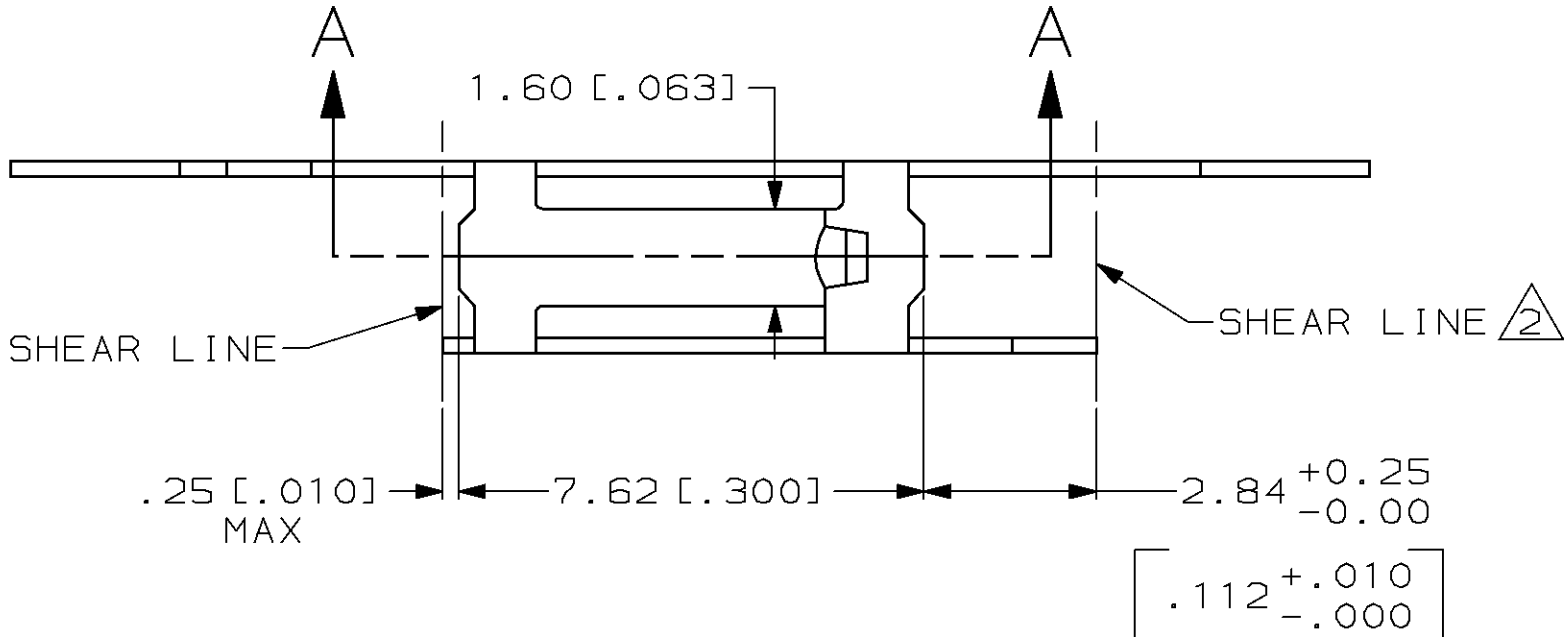
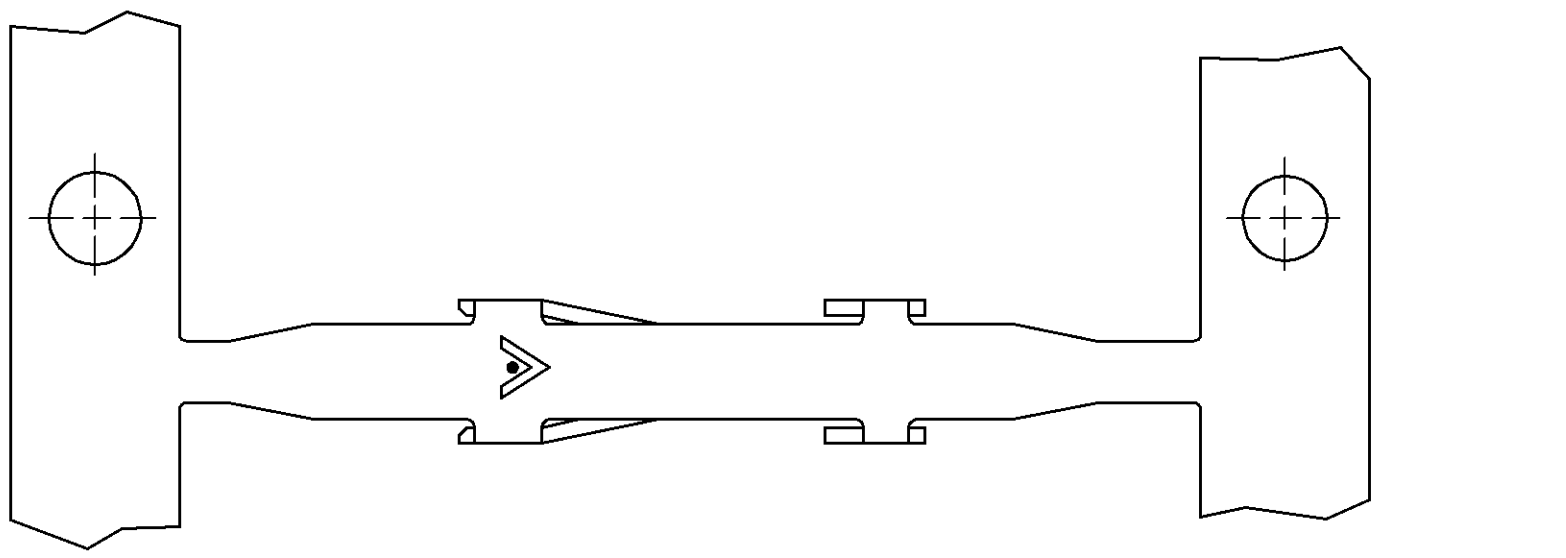
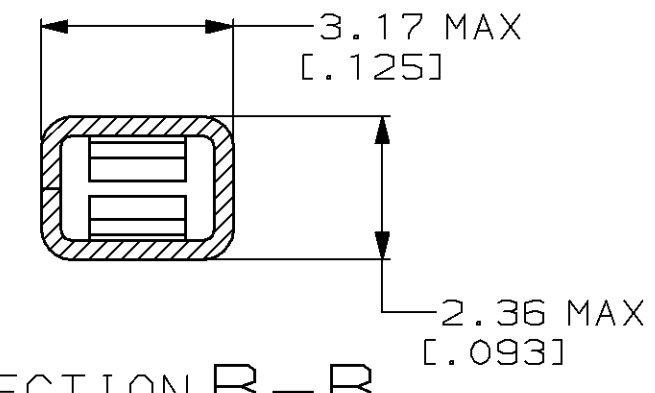
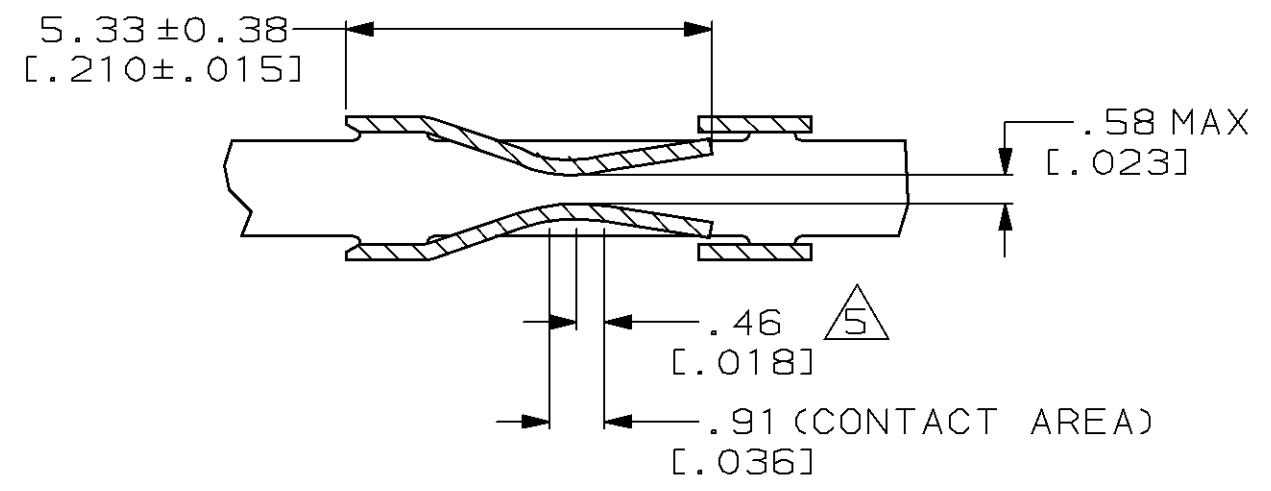

OBSOLETE	4	1	86441-3	86448-4
OBSOLETE	3	1	86441-2	86448-2
	1	1	86441-1	86448-1
			FINISH MATERIAL	LOOSE PIECE PART NO.
				PART NUMBER

		PART NO	
DO NOT SCALE PRINT. UNLESS SPECIFIED DIMENSIONS IN mm [INCHES] TOLERANCES ON:	DR 12-28-96 E. BRANDBERG	AMP Incorporated Harrisburg, PA 17105-3608	
2 PLC DEC ± -	CHK 12-28-96 J. HERRINGTON		
3 PLC DEC ± -	APPD 12-28-96 J. HERRINGTON	NAME	
ANGLES ± -	APPD 12-28-96 D. TROUT	FEMALE CONTACT, VERTICAL, TYPE "B", MOD I (HIGH PRESSURE)	
MATERIAL	PRODUCT SPEC	SIZE	CAGE CODE
SEE TABLE	-	C	00779
FINISH	APPLICATION SPEC	DRAWING NO	
SEE TABLE	-	C=86448	
WEIGHT	-	SCALE	SHEET
		8:1	1 OF 1

THIS DRAWING IS A CONTROLLED DOCUMENT FOR AMP INCORPORATED. IT IS SUBJECT TO CHANGE AND THE CONTROLLING ENGINEERING ORGANIZATION SHOULD BE CONTACTED FOR THE LATEST REVISION.